



MANUAL PART NUMBER: 400-0020-003
PRODUCT REVISION: 0

MX2416RM/MX2414RM

6/(4) - IN, 1 - OUT

VGA/MAC SWITCHER

USER'S GUIDE

INTRODUCTION

Thank you for purchasing the **MX2416RM** Switcher. We are sure you will find it a reliable and useful product.

Superior performance for the right price backed by solid technical and customer support is what we have to offer.

The product you are holding in your hands is designed using state-of-the-art technology and is superior to anything available on the market. You will find this and our other products reliable, long lasting, and simple to operate.

We are committed to providing our customers with solutions to the most demanding audio-visual installations at very competitive pricing.

We appreciate your selection of our products and are confident that you will join the ranks of our many satisfied customers throughout the world.

This manual covers:

MX2416RM – 6 – in, 1 - out VGA/MAC Switcher

MX2414RM – 4 – in, 1 - out VGA/MAC Switcher

TABLE OF CONTENTS

	Page
PRECAUTIONS / SAFETY WARNINGS	2
GENERAL	2
RACK MOUNT SAFETY GUIDELINES	2
INSTALLATION	2
CLEANING	2
FCC / CE NOTICE	2
ABOUT YOUR SWITCHER	3
TECHNICAL SPECIFICATION	3
DESCRIPTION OF MX2416RM	4
SELECT INPUT	5
AUTO SWITCH MODE BUTTON	5
STAND BY / ALL CHANNELS OFF BUTTON	5
RESET BUTTON	5
BEEP ON/OFF BUTTON	5
POWER UP DEFAULT SET	6
ANALOG OUTPUT	6
POWER SUPPLY	6
BI-DIRECTIONAL SWITCHING	6
APPLICATION DIAGRAM	6
INSTALLING YOUR SWITCHER	7
OPERATION	7
RS-232 CONTROL	7
RS-232 PROTOCOL	8
MASTER-SLAVE CONFIGURATION	9
CONTACT CLOSURE (ONE WIRE ANALOG) CONTROL	9
MANUAL LOOP CONTROL	10
LOOP CONTROL WITH RS-232 COMMAND ...	10
ACCESSORIES	11
FREQUENTLY ASKED QUESTIONS	12
TROUBLESHOOTING GUIDE	12
ALTINEX POLICY	13
LIMITED WARRANTY	13
RETURN POLICY	13
CONTACT INFORMATION	13

PRECAUTIONS / SAFETY WARNINGS 1

Please read this manual carefully before using your **MX4216RM** Switcher. Keep this manual handy for future reference. These safety instructions are to ensure the long life of your **MX2416RM** and to prevent fire and shock hazard. Please read them carefully and heed all warnings.

1.1 GENERAL

- Unauthorized personnel shall not open the unit since there are high-voltage components inside.
- Qualified Altinex service personnel, or their authorized representatives must perform all service.

1.2 SAFETY GUIDELINES FOR THE RACK-MOUNTING OF THE MX2416RM

- Maximum operating ambient temperature is 35 (degrees C).
- Never restrict the airflow through the device's fan or vents.
- When installing equipment into a rack, distribute the units evenly. Otherwise, hazardous conditions may be created by an uneven weight distribution.
- Connect the unit to a properly rated supply circuit.
- Reliable Earthing (Grounding) of Rack-Mounted Equipment should be maintained.

1.3 INSTALLATION

- For best results, place the **MX2416RM** Switcher on a flat, level surface in a dry area away from dust and moisture.
- To prevent fire or shock, do not expose this unit to rain or moisture. Do not place the **MX2416RM** Switcher in direct sunlight, near heaters or heat radiating appliances, or near any liquid. Exposure to direct sunlight, smoke or steam can harm internal components.
- Handle the **MX2416RM** Switcher carefully. Dropping or jarring can damage internal components.
- Do not place heavy objects on top of the **MX2416RM**. If the **MX2416RM** is to a table or wall, use only an Altinex made mounting

accessories like rack mount shelf **DA1298RM** or rack mount ears **DA1299RM** and cables for optimum setup.

- To turn off the main power, be sure to remove the cord from the power outlet. The power outlet socket should be installed as near to the equipment as possible, and should be easily accessible.
- Do not pull the power cord or any cable that is attached to the **MX2416RM** Switcher.
- If the **MX2416RM** Switcher is not to be used for an extended period of time, disconnect the power cord from the power outlet.

1.4 CLEANING

- Unplug the **MX2416RM** power cord before cleaning. Clean surfaces with a dry cloth. Never use strong detergents or solvents such as alcohol or thinner. Do not use a wet cloth or water to clean the unit.

1.5 FCC / CE NOTICE

- This device complies with Part 15 of the FCC Rules. Operation is subject to the following two conditions: (1) This device may not cause harmful interference, and (2) this device must accept any interference received, including that may cause undesired operation.
- This equipment has been tested and found to comply with the limits for a Class A digital device, pursuant part 15 of the FCC Rules. These limits are designed to provide reasonable protection against harmful interference when the equipment is operated in a commercial environment. This equipment generates, uses, and can radiate radio frequency energy and, if not installed and used in accordance with the instruction manual, may cause harmful interference to radio communications. Operation of this equipment in a residential area is likely to cause harmful interference in which case the user will be required to correct the interference at his own expense.
- Any changes or modifications to the unit not expressly approved by Altinex, Inc. could void the user's authority to operate the equipment.

ABOUT YOUR SWITCHER

2

The **MX2416RM** is a 6-in 1-out relay switcher designed to allow the non-simultaneous connection of up to six PC or six MAC computer video sources to a single monitor or projector. The **MX2416RM** is controllable using its built-in front panel, through RS-232, or through contact closures. Contact closure control requires the use of an optional adapter, part # **RC5204CC**.

The **MX2416RM** offers both 15-pin HD type connectors and 15-pin D type connectors. If used to switch VGA (VGA/SVGA/XGA) video signals, the 15-pin HD connectors should be used; if used to switch MAC type video signals, the 15-pin D connectors should be used.

The **MX2416RM** uses relays internally and therefore may be used to switch other signal types as well, including RGBHV, RGBS, RGsB, Component Video (Y, R-Y, B-Y), S-Video (Y/C), Composite Video, Audio, and even RS-232, assuming the appropriate adapter cable is used.

Since the **MX2416RM** uses relays internally, it can also be used bi-directionally – a signal can be routed “backwards” through the switcher to allow a single source to be connected to as many as six displays.

The **MX2416RM** offers a 9-pin control port, which provides a means of interconnection for RS-232 and contact closure control as well as other special features. For instance, when multiple **MX2416RM** units are looped together to create a larger switcher, two pins on the 9-pin control ports can be connected to make the switcher respond as a single unit. Using a similar method, multiple **MX2416RM** units can be made to operate in a Master-Slave mode, with all units responding to a single button selection.

Although very affordable as a stand-alone VGA or MAC Switcher, the **MX2416RM**'s dual connector compatibility makes it ideal for rental applications or for other types of multifunction use.

Using optional hardware, a single **MX2416RM** can be rack-mounted by itself or two units can be rack-mounted side-by-side.

TECHNICAL SPECIFICATIONS

3

FEATURES/ DESCRIPTION	MX2416RM/ MX2414RM
GENERAL	
Inputs	6/(4 for MX2414RM)
VGA Input Connector	Six 15-pin HD Female
MAC Input Connector	Six 15-pin D Female
Outputs	1
VGA Output Connectors	15-pin HD Female
MAC Output Connectors	15-pin D Female
Compatibility	VGA/SVGA/XGA/UXGA/ MAC, RGBHV, RGBS, RGsB, Component Video (Y, R-Y, B-Y), S-Video (Y/C), Composite Video,

Table 1. **MX2416RM/MX2414RM** General

MECHANICAL	MX2416RM /MX2414RM
Material	0.1" Al
Finish	Gray
Top Panel	Lexan
Height (inches)	3.38in (86mm)
Width (inches)	8.50in (216mm)
Depth (inches)	4.38in (111mm)
Weight (pounds)	3.0lbs (1.36kg)
Ship Weight (pounds)	4.0lbs (1.82kg)
T° Operating	10°C-35°C
T° Maximum	50°C
Humidity	90% non-condensing
MTBF (calculations)	40,000 hrs

Table 2. **MX2416RM/MX2414RM** Mechanical

ELECTRICAL	MX2416RM/ MX2414RM
Input Video Signal	
Analog Signal	+/-10V p-p max
Impedance	75 Ohms
Input Sync Signal	
Composite Sync	TTL(+/-), Analog 0.3-1.0V
Sync on Green	-0.3V
Impedance	pass-through
Output Video Signals	
Analog Signal	+/-10V p-p max
Fall/Rise Time (ns)	1.9
Impedance	75 Ohms (pass-through)
Output Sync Signal	
Composite Sync	TTL(+/-), Analog 0.3-1.0V (not buffered)

3

SWITCHERS

Sync on Green	-0.3V
Impedance	pass-through
Frequency Compatibility	
Typical Video Bandwidth	400 MHz @ -3 dB
Horizontal	15-200 kHz
Vertical	30-190 Hz

Cross-talk	-48dB @ 10 MHz
Coupling	DC
Power	
External Power Adapter	90-140V/200-240V
Power Consumption	12 watts max.

Table 3. MX2416RM/MX2414RM Electrical

DESCRIPTION OF MX2416RM 4

BACK PANEL OF MX2416RM

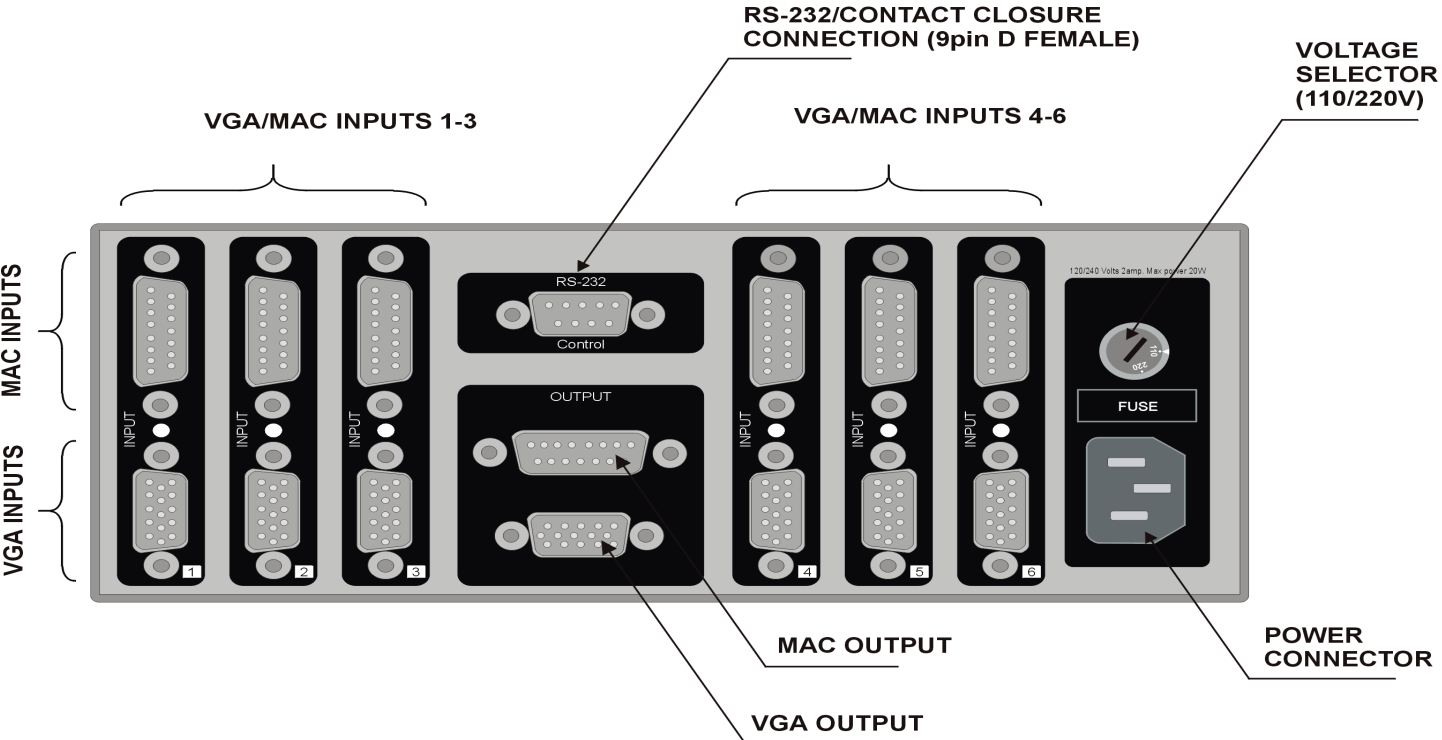

FRONT PANEL OF MX2416RM

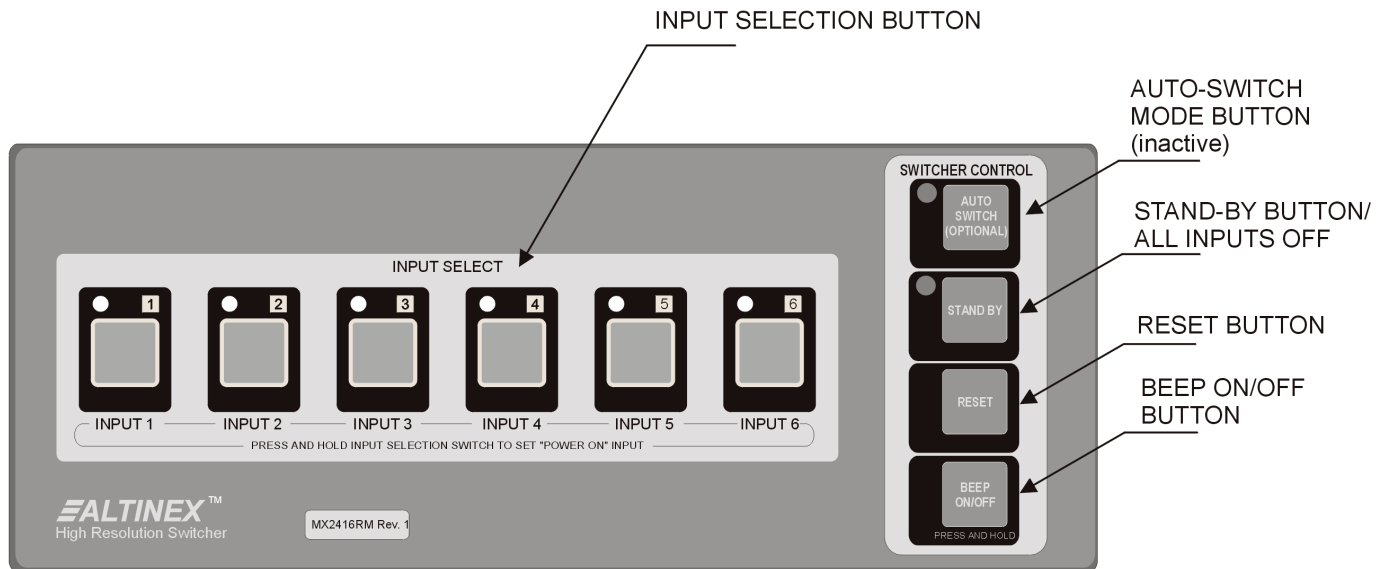

The front panel of the **MX2416RM** provides access to essentially all of the switcher's capabilities. In addition to standard switching functions, the unit has control and switching functions that could be very useful in a variety of special applications.

4.1 SELECT INPUT

When buttons 1 through 6 are pressed, the corresponding INPUT will be selected and displayed. LED's on the front and rear panel will light simultaneously to indicate which selection has been made.

4.2 AUTO SWITCH MODE BUTTON

This function is non-operational at this time and is reserved for future upgrades.

4.3 STAND BY / ALL CHANNELS OFF BUTTON

This function allows a user to turn OFF all input signals. It is very useful when the **MX2416RM** Switcher is used in applications where there is a need to turn the display or the source OFF. Press this function key (F2) to switch to a no signal condition. The LED next to the F2 function key will light to indicate that the switcher is in this mode. To

resume input select switching, simply press the desired INPUT.

4.4 RESET BUTTON

This function allows a user to RESET the switcher without unplugging the unit. Press the function key RESET (F3) and hold it for 2 seconds. When you hear a beeping sound, release the key. All of the LED's will flash simultaneously. The switcher is now reset. All previous defaults, such as power on channel default and other user settings are maintained.

4.5 BEEP ON/OFF BUTTON

This function allows a user to have audible feedback when buttons are pressed. The factory default is beep ON; however, in some applications, sound may be undesirable. To disable sound, press this function key (F4) and hold it for approximately 2 seconds until a beeping sound is heard. The function is now disabled. To enable it, repeat the same steps. The setting is stored in the memory and is maintained during power up sequence.

4.6 POWER UP DEFAULT SET

This function allows a user to select the channel that will be ON at power up. To select the default channel press the selected channel switch and hold it for approximately 2 seconds until you hear a beeping sound. If the unit is turned off and turned back on, the LED of the selected channel should light.

4.7 ANALOG OUTPUT

The analog output of the **MX2416RM** can be used for controlling several switchers simultaneously. The analog amplifier drives analog output pin 9 on a 9-pin "D" connector. The output can swing from 0 V to approximately 5.0 V. The output impedance of this pin is 100 Ohms and it can sink or source up to 5 mA of current. By using this output, several switchers can operate in gang mode. To do this, the analog output of the master switcher (pin 9) is connected to the analog input of the slave switchers (pin 9). Now, every time a channel is selected on the master switcher, the output voltage of the analog output will be set to switch all other switchers into the same channel. The simplicity of this approach is that only 2 wires (one to pin 9 and one to ground) are required to connect and control all of the switchers. The selection of channels can also be accomplished by RS-232 on the master switcher with all slave switchers connected through the analog control pin. A maximum of 4 switchers can be connected in this configuration.

4.8 POWER SUPPLY

The **MX2416RM** Switcher has 5 V power supply available on pin 8 of the 9-pin "D" connector. This voltage can be used to drive external circuits or as a pull up voltage for open collector type outputs. The total current on this pin should not exceed 150 mA of continuous operation or 500 mA for 5 minutes.

4.9 BI-DIRECTIONAL SWITCHING

The **MX2416RM** Switchers use very high bandwidth relays to provide you with a 400 MHz bandwidth. Each input, when not selected, is terminated to a 75-Ohms resistor. This is done to make sure that video lines are always terminated whether a channel is selected or not.

In addition to forward connection, the **MX2416RM** can be hooked up in a reverse direction. In this configuration one video source is selectively sent to each of the video monitors. This capability is referred to as bi-directional switching. In this configuration only one display device can be operational at any given time.

APPLICATION DIAGRAM

5

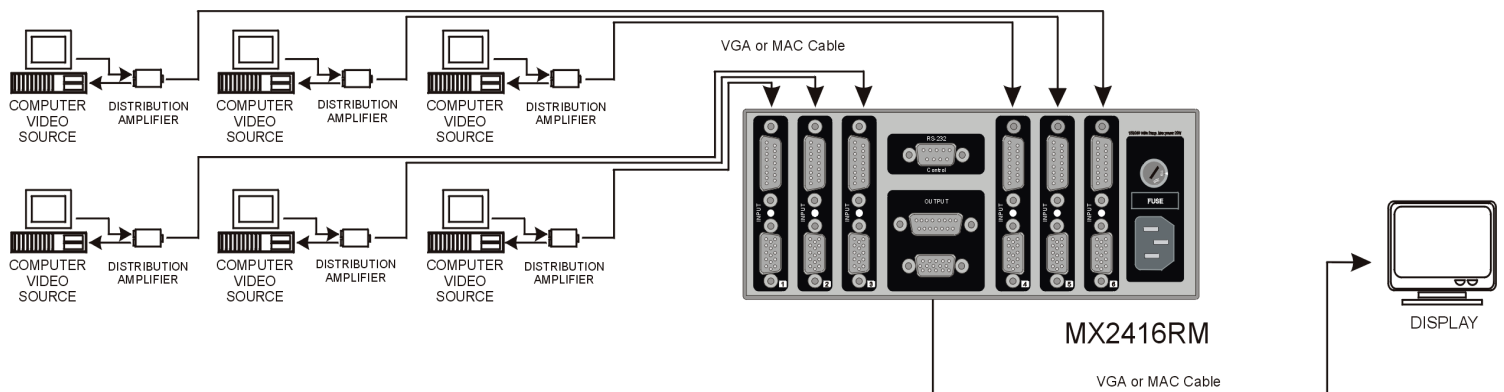

6

INSTALLING YOUR SWITCHER 6

- Step 1.** Make sure that the power input is set to the proper AC voltage in your country. An incorrect setting can result in unit damage not covered by warranty.
- Step 2.** Connect the power cord to the unit and plug it into the power outlet.
- Step 3.** Connect the cables from the video sources (computers) to the input channels and connect the output channel to the display device (i.e. monitor or projector)
- Step 4.** If a control system is used to control the unit connect RS-232 port to the control system's RS-232 card. An improper hook up may result in RS-232 interface damage.
- Step 5.** Verify that the picture quality on the display is good. If you are not receiving a signal, make sure that the display is compatible with the resolution of the computer graphics card.

Contact Closure control requires the use of part # **RC5204CC** Cable.

CONGRATULATIONS! YOU ARE DONE.

If you experience any problems, please call 1-800-258-4623 or 1-714-990-2300 for international calls.

OPERATION 7

7.1 RS-232 CONTROL

The **MX2416RM** Switcher uses a female 9-pin HD connector on its rear panel that allows access to a variety of control capabilities.



PIN No.	PIN Designation
1	No connection
2	RS-232 Transmit
3	RS-232 Receive
4	No connection
5	Ground
6	Multiple Switcher Loop Control
7	Analog Switch Voltage Input
8	+5 V (150 mA max)
9	Analog Voltage Output

9-pin D connector

It is generally recommended to select a single method of control for each application, as the activation of several different controls simultaneously may cause unpredictable results.

The majority of control systems and computers used in presentation system applications use the RS-232 communications standard.

To connect the **MX2416RM** Switcher to a control system or computer for RS-232 Control, only three pins are required on each port: Transmit (TX), Receive (RX), and Ground (GND). The Transmit pin from the control system or computer must be connected to the Receive pin of the switcher control port; do not connect Transmit to Transmit or Receive to Receive.

The following are typical cable wiring pin outs:

IBM PIN No.	MX2416RM PIN No.
3	2
2	3
7	5

Connection IBM-PC 25-pin D to **MX2416RM** 9-pin D
Note: 5, 6, 20 shorted together in IBM side only.

IBM PIN No.	MX2416RM PIN No.
2	2
3	3
5	5

Connection IBM-PC 9-pin D to **MX2416RM** 9-pin D
 Note: 4, 6, 8 shorted together in IBM side only.

Port setting preferences for the control system or computer being used to control the switcher should be set as follows:

BAUD RATE (Bits per second)	2400
Data bits	8
Parity	None
Stop Bits	1

There is no software or hardware flow control implemented. The RS-232 input has a 6-character buffer and will not execute additional commands until the previous command is fully processed.

7.2 RS-232 PROTOCOL

[INP0]	All channels OFF
[INP1]	Select Input 1
[INP2]	Select Input 2
[INP3]	Select Input 3
[INP4]	Select Input 4
[INP5]	Select Input 5
[INP6]	Select Input 6
[RSET]	Reset unit to user defaults
[VERN]	Returns firmware version numbers

Inputs 5 & 6 are not selectable on the **MX2414RM**

Commands must be issued as shown, in ALL CAPS and with the brackets [] included in the command string. After processing a valid command, an [OK] string will be returned. A command echo will also follow the [OK].

For instance, a command of [INP1] would return [OK][INP1]. The [VERN] command will return the corresponding software version being used by the switcher, such as an error string, [ERR] will be returned.

If the control system being used is not setup to wait for the [OK] string, it is important to include a 100 milliseconds delay between each command.

The **MX2416RM** Switcher is also designed to send feedback commands from the switcher to the control system when the buttons on the front panel of the switcher are pressed.

The feedback codes are as follows:

Key pressed	Description	Feedback Code
1	Input Select	[INP1]
2	Input Select	[INP2]
3	Input Select	[INP3]
4	Input Select	[INP4]
5	Input Select	[INP5]
6	Input Select	[INP6]
STAND BY	All Outputs OFF	[INP0]
RESET	Reset	[RSET][INPx]

Inputs 5 & 6 are not selectable on **MX2414RM**.

The following commands are added to the standard set of commands in order to facilitate control of multiple units using a single RS-232 control port. These commands are available on the switcher that has firmware revision number: 2.0. Use [VERN] commands to determine the firmware revision. These commands add additional flexibility to the switcher.

[InnOmm]

nn -	Input Number 00 to 99
mm -	Output Number 01-99

This command connects any input to any output. The switching occurs as soon as the command is completed. The input 00 is used to disconnect a particular output from any input. For example, command [I00O01] will disconnect output 1 from any input.

[OUTmm]

This command sets the switcher to respond to specific output only. The default setting is output 1.

[SETxnnmm]

- x** - select input number
- nn** - Minimum input number
- mm** - Maximum input number

This command is designed to allow the **MX2416RM** to program each input to respond to a selected range of input commands.

For example, if command [SET10104] is issued, then the following commands will select only Input 1: [I01O01], [I02O01], [I03O01], and [I04O01]. In other words a range of I/O commands can address the same input. The default settings for each of the inputs are as follows Input 10101, Input 20202, Input 30303, Input 40404, Input 50505, and Input 60606.

7.3 MASTER-SLAVE CONFIGURATION

These feedback codes allow multiple **MX2416RM** Switchers to be connected in a Master-Slave configuration, if desired.

When the control ports of two units are connected as shown below, the slave unit duplicates the actions of the master unit. The same unit can still be controlled from its front panel or through another RS-232 control.

MX2416RM 9-pin D Master PIN No.	MX2416RM 9-pin D Slave PIN No.
2	3
5	5

Master-Slave Control Port Connection

A Master-Slave configuration can be achieved also by Analog Switch Voltage using pin#9 and pin#7.

MX2416RM 9-pin D Master PIN No.	MX2416RM 9-pin D Slave PIN No.
9	7
5	5

Master-Slave Analog Switch Voltage Connection

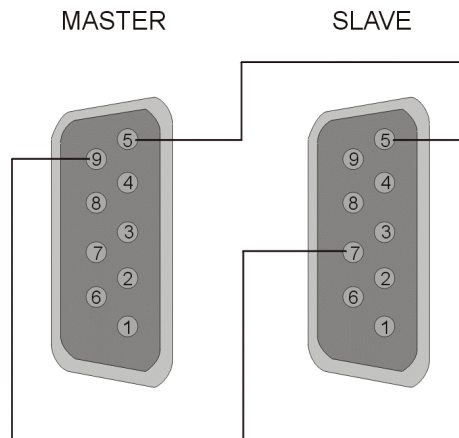

With this configuration the Master unit has ultimate control over slave unit.

7.4 CONTACT CLOSURE (ONE WIRE ANALOG) CONTROL

The one wire control is an alternative to a multi-wire contact closure control. This control pin allows you to select different channels based on the DC voltage level on the pin 7 of the 9 pin D connector. Internally pin 7 is pooled up to 5 volts by 10k resistor. Thus, by selecting proper resistor values connected to ground any channel can be selected. Although the channel selection by the relay contact is latching and will maintain the last relay selected channel, it is recommended that momentary contact closures are not used. A typical resistor values and wires connections are shown below.

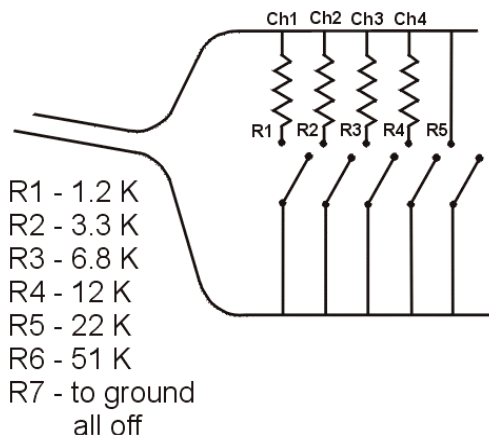

In some cases it may be preferable to use a seven conductor wire to control the switcher with contact closures. The **RC5204CC** adapter is available to

SWITCHERS

accommodate this need. The pin-outs for this adapter are as follows:

9 pin "D" Male	Description	9 pin "D" Female	Input
7	1.2K	1	1
7	3.3K	2	2
7	6.8K	3	3
7	12K	4	4
7	22K	5	5
7	51K	6	6
7	0 short	7	NONE
5	Ground	9	

The following voltages apply for selecting the required channel:

Input number	min. (V)	nom. (V)	max. (V)
1	0.35	0.55	0.75
2	1.07	1.27	1.47
3	1.80	2.00	2.20
4	2.52	2.72	2.92
5	3.25	3.45	3.65
6	3.97	4.17	4.37

These voltage levels can be set using analog outputs from different control systems or spare dimmer control outputs.

7.5 MANUAL LOOP CONTROL

Loop control is used when multiple units of the **MX2416RM** are connected to form a single switcher. When the input channel button is pressed the loop control pin is internally grounded and the **MX2416RM** Switcher selects INPUT 4 as the default input.

In this configuration, loop control pin 6 on the 9 pin D connector is connected to the same pin on all switchers.

MX2416RM LOOP	MX2416RM LOOP
6	6
5	5

MX2416RM 9-pin "D" Loop

The loop control pin has an internal 100k resistor to +5volts. This limits the number of switchers that can be looped to a maximum of 10 switchers that can be daisy chained together using this method.

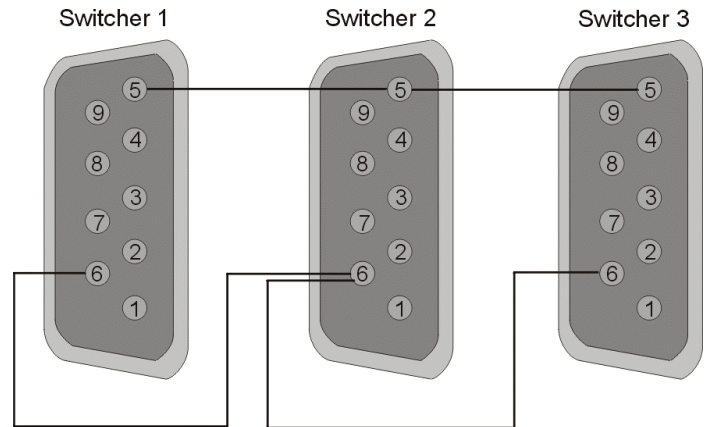

More specifically, the output of one switcher is connected to INPUT 6 of the next switcher. Once loop control is enabled these switchers will automatically switch video signals to the output of the second switcher through INPUT 6. Keep in mind that you are always going to have one less input than the total number of inputs available on all switchers. The figure above is for an 11-in 1-out switcher.

7.6 LOOP CONTROL WITH RS-232 COMMAND

When multiple **MX2416RM** units are connected to form a single switcher and RS-232 commands are used to control these units, please connect units according to following diagram.

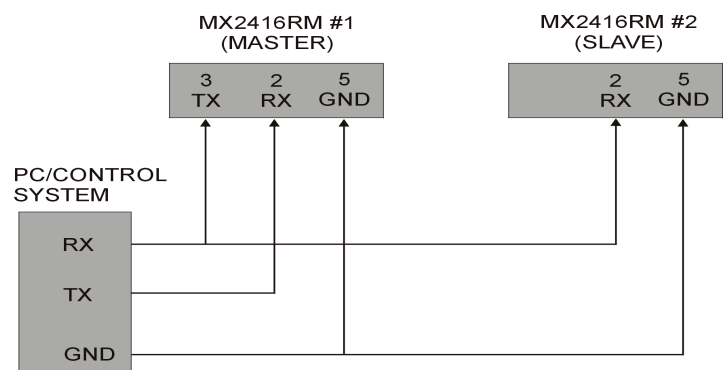

If you want to make 11 by 1 switcher using two 6 by 1 switchers, the following commands need to be used to control these switchers:

Input 1 through Input 6 [OUT01]
 Input 7 through Input 11 [OUT02]

This will setup each switcher as a different output number. To control the switchers use following commands (connect the transmit line from the control system to the receive line on both switchers):

- [I01O01] Select input number 1
- [I02O01] Select input number 2
- [I03O01] Select input number 3
- [I04O01] Select input number 4
- [I05O01] Select input number 5
- [I06O01] Select input number 6
- [I01O02] Select input number 7
- [I02O02] Select input number 8
- [I03O02] Select input number 9
- [I04O02] Select input number 10
- [I05O02] Select input number 11.

ACCESSORIES 8

Model No.	Description
TABLE MOUNT HARDWARE	
TM1276	Table Mount bracket for 2U ½ Rack-Wide
RACK MOUNTING ACCESSORIES	
DA1298RM	Rack mount shelf for two units side by side
DA1299RM	Rack ears for single unit.
CONTROL CABLES	
RC5204CC	Contact Closure Adapter 6 ft
RC5207CC	Master-Slave Control cable
HIGH RESOLUTION VGA CABLE	
CB3703MR	3 feet VGA Male to Male
CB3706MR	6 feet VGA Male to Male
CB3715MR	15 feet VGA Male to Male
CB3725MR	25 feet VGA Male to Male
CB3750MR	50 feet VGA Male to Male
CB3775MR	75 feet VGA Male to Male
CB37100MR	100 feet VGA Male to Male
CB37150MR	150 feet VGA Male to Male
HIGH RESOLUTION VGA CABLE	
CB3903MR	3 feet VGA Male to Female
CB3906MR	6 feet VGA Male to Female
CB3915MR	15 feet VGA Male to Female
CB3925MR	25 feet VGA Male to Female
CB3950MR	50 feet VGA Male to Female
CB3975MR	75 feet VGA Male to Female
CB39100MR	100 feet VGA Male to Female
CB39150MR	150 feet VGA Male to Female
HIGH RESOLUTION MAC CABLE	
CB3403MR	3 feet MAC Male to Male
CB3406MR	6 feet MAC Male to Male
CB3415MR	15 feet MAC Male to Male
CB3425MR	25 feet MAC Male to Male
CB3450MR	50 feet MAC Male to Male
CB3475MR	75 feet MAC Male to Male
CB34100MR	100 feet MAC Male to Male
CB34150MR	150 feet MAC Male to Male
HIGH RESOLUTION MAC CABLE	
CB3603MR	3 feet MAC Male to Female
CB3606MR	6 feet MAC Male to Female
CB3615MR	15 feet MAC Male to Female
CB3625MR	25 feet MAC Male to Female
CB3650MR	50 feet MAC Male to Female
CB3675MR	75 feet MAC Male to Female

CB36100MR	100 feet MAC Male to Female
CB36150MR	150 feet MAC Male to Female
POWER CABLES	
PC5301US	Power cable for US
PC5302US	Power cable for U.K.
PC5303US	Power cable for Australia
PC5304US	Power cable for Germany

FREQUENTLY ASKED QUESTIONS 9

No	Question	Answer
1	When I press F1 nothing happens. What is a purpose of this function?	The F1 function is reserved for future use. It does not perform any functions at the present time.
2	What is the LED next to the F1 button used for?	This LED is also reserved for future use. It is currently non-operational.
3	When I press the RESET button, the switcher does not respond. Why?	You must <u>press and hold</u> the button for approximately 2 seconds, until you hear a beeping sound and all of the LED lights flash. This is designed to avoid accidental resetting.
4	Can the MX2416RM be rack mounted?	The MX2416RM can be rack mounted by itself or two units side by side. The width of the unit is 1/2 rack wide. Altinex offers rack mount ears for single unit mounting (part# DA1299RM) and rack shelf for two unit mounting (part# DA1298RM).
5	Can the MX2416RM be used to pass Composite Video, S-Video or Component Video?	Yes, simply use the corresponding channels to pass the signals (e.g. For composite video, you may use the red input channel and the red output channel, or you can use the blue input channel and the blue output channel). Since the MX2416RM is a

		relay switcher, it can be used as a contact closure control or to switch virtually any type of video signal.
6	Can the MX2416RM Switcher be used outside of the United States	Yes, the MX2416RM uses a universal internal power supply, enabling it to be used throughout the world. Please make sure to have the voltage setting in the correct position and please make sure to use the proper adapter cable for the country where it will be used. Adapter cables for several countries are available through Altinex.
7	How do I control several switchers with one RS-232 card in a control system?	You can control multiple switchers with one card at this time. The unit has ID codes and can be differentiated by the control system. Call Altinex if this requirement is important for your system.
8	Can I use contact closure to control the switcher?	A special cable that plugs into the RS-232 port and converts contact closure into analog control is available. This is RC5204CC cable is made by Altinex on request.
9	Can the MX2416RM switcher be looped with other MX2416RM Switchers?	Yes, in exactly the same way as described in this manual when the MX2416RM is slaved to another MX2416RM .

TROUBLESHOOTING GUIDE 10

- Please make sure that the input signal formats are same for input (source) and output (display).
- Please make sure that the input signal amplitude levels are as follows:
 1. RED, GREEN, BLUE is less than 10 V.

2. SYNC is less than 1.0 V and more than 0.3 V.
- Please use the appropriate input voltage 110 VAC or 220 VAC.
 - Please make sure that the proper quality of cables is used. We recommended Altinex made cables for the best results.
 - If a problem shows up after continuous usage at higher voltage, higher temperature, higher humidity, or at other extreme environmental conditions, please correct the problem.
 - Please reset the unit by pressing the RESET key for more than 2 seconds, if a problem exists with the switcher.
 - Make sure that all channels (inputs) are ON (i.e. RED LED is OFF next to the STAND BY key).
 - If you are using any control software or hardware to control the **MX2416RM**, then first verify operation of the unit using MX Control software available from the Altinex web-site: www.altinex.com. Make sure that all cables are made according to manual, where the RX pin of the **MX2416RM** is connected to the TX pin of the computer.
 - If you are controlling the unit by the RS-232 command, make sure there is a minimum delay of 100 milliseconds before sending a next command.
 - If you have multiple **MX2416RM** Switchers connected in Master-Slave mode or Loop-Control mode, please make sure to have a connection of RS-232 port connected according to the manual.

ALTINEX POLICY

11

11.1 LIMITED WARRANTY

Altinex warrants that its products and cables are free from defects in materials under normal use and service. This warranty is limited to repairing at company's factory any part or parts of the product, which upon company's examination shall disclose to be, thus defective. Products considered defective should be returned to company with transportation charges pre-paid within 2 years (90 days for cables) from date of shipment to the purchaser. The warranty is expressly instead of all

other warranties expressed or implied. Altinex neither assumes nor authorizes any other person to assume for it any other liability in connection with the sale of the products. This warranty shall not apply to any product that shall have been repaired or altered outside of company's factory in any way so as, in its judgment, to affect its stability or reliability, or that has been subject to misuse, negligence or accident.

11.2 RETURN POLICY

It is very important that you receive products that you have ordered and that this product fulfills your need. In the unlikely event that an Altinex product needs to be returned please follow the policies below:

Altinex will accept product returns for a period of 30 days from authorized Altinex dealers. Products should be returned in an unopened package.

If a product has been opened, the restocking fees will apply. For the restocking fee amount, please contact an Altinex Sales Representative.

If the product is in your possession for more than 30 days, the restocking fees will apply.

Altinex will not accept any returns on cables or custom products.

If your product is in warranty and needs service, contact the Altinex Sales Department for an RMA (Return Material Authorization). Products returned without an RMA number may experience a delay in service.

If your product is out of warranty and needs service, contact the Altinex Sales Department for an RMA (Return Material Authorization). Products returned without an RMA number may experience a delay in service. The service charges will be quoted to you before the actual repairs are done.

11.3 CONTACT INFORMATION

Sales Department

Phone: 714-990-2300

Fax: 714-990-3303

Accounting Department

Phone: 714-990-6088

Fax: 714-990-5778